

TRAIL Level 1 Open

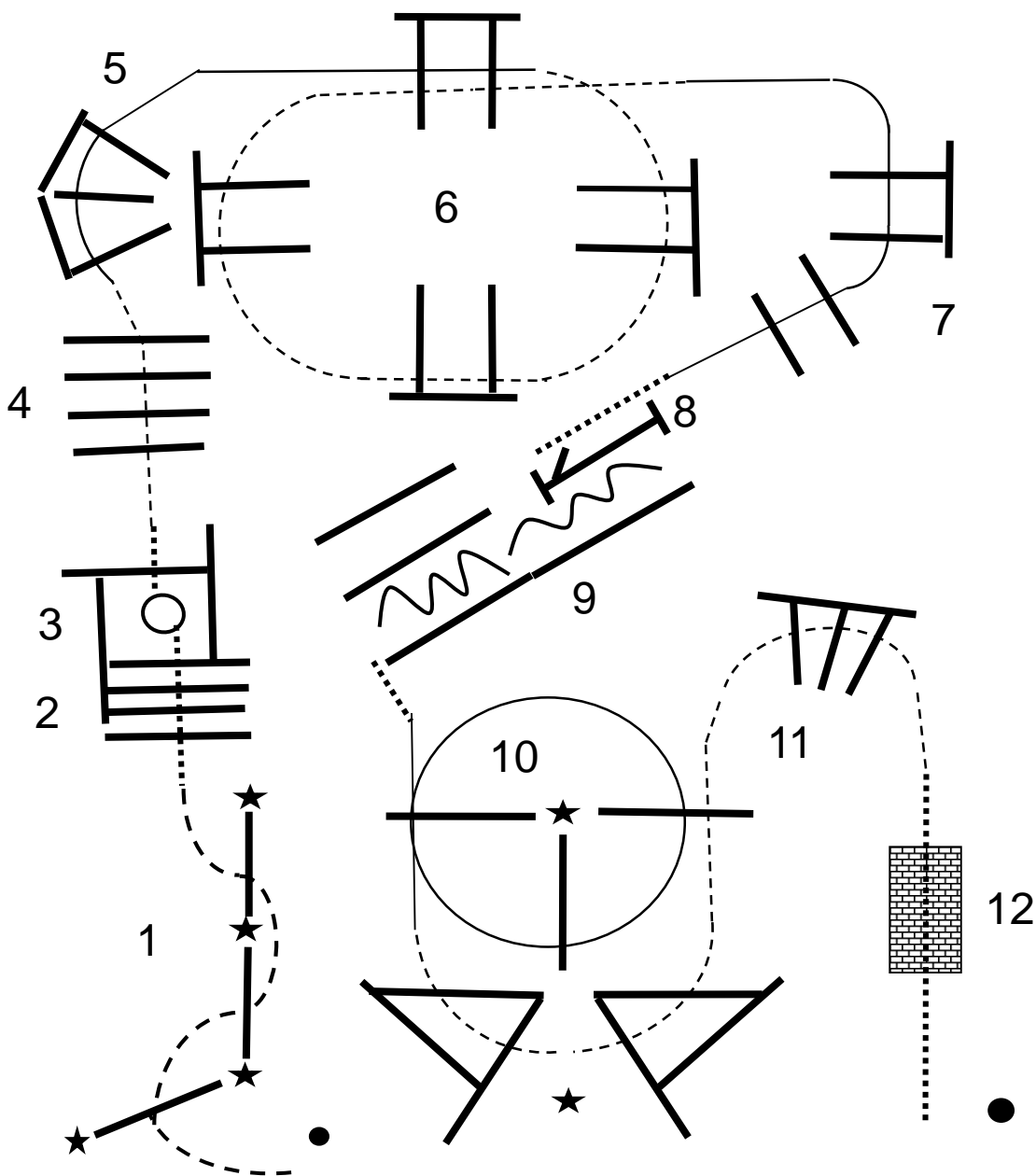

- 1 Jog over
- 2 walk over
- 3 360° either side- walk out
- 4 Jog over
- 5 RL Lope over
- 6 Jog over
- 7 RL lope over
- 8 Work gate
- 9 Back up
- 10 LL Lope over
- 11 Jog over
- 12 Walk bridge

<ul style="list-style-type: none"> → Lope / Galop - - - Jog · · · Walk / Pas ● Marker -/cône 	<ul style="list-style-type: none"> → Extended Lope / Galop allongé - - - Extended Jog / Trot ↻ Turn / pivot ▲ Backup / reculer
--	--

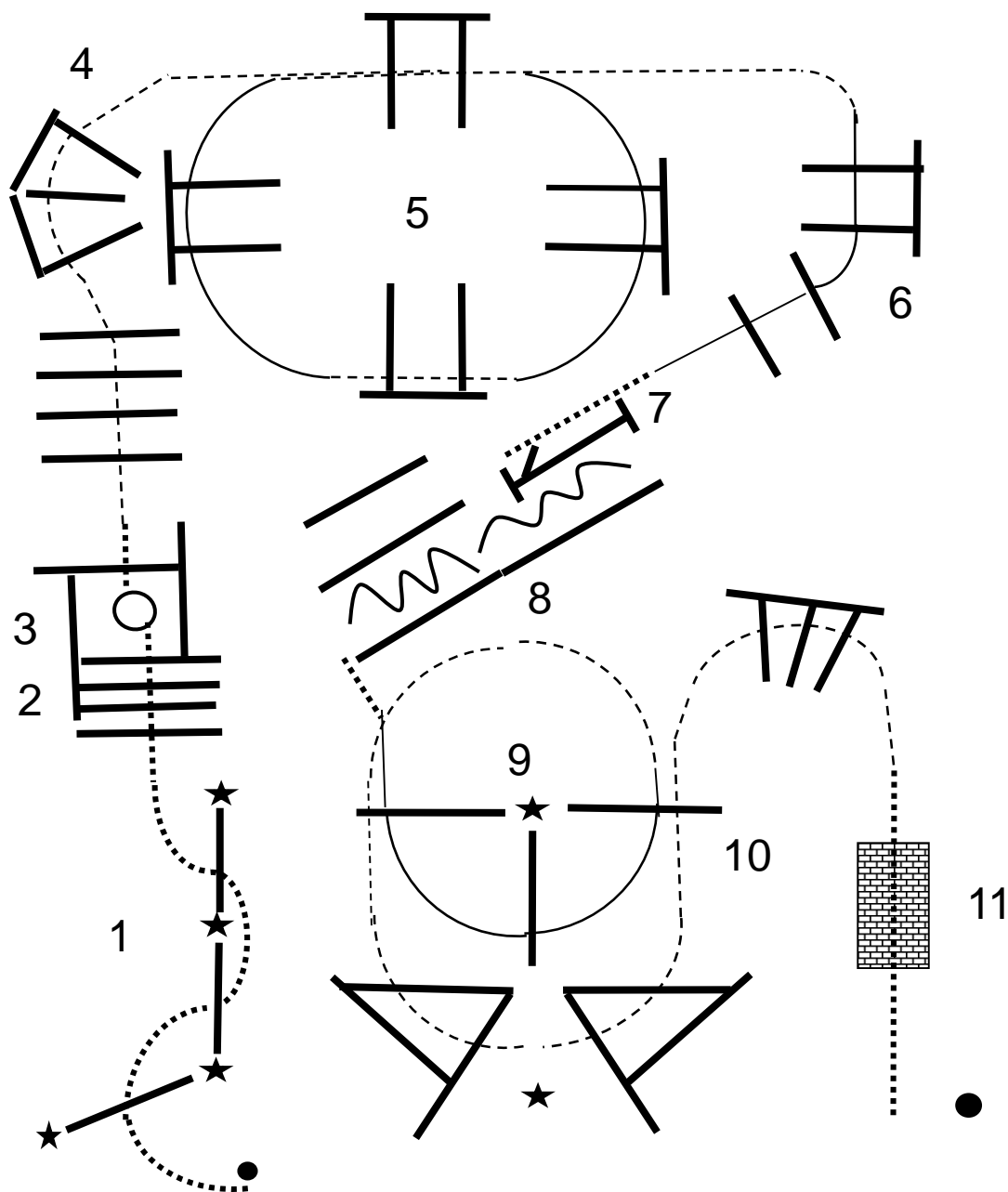

- 1 Walk over serpentine
- 2 Walk over in
- 3 360° either side- walk out
- 4 Jog over
- 5 RL Lope - jog - RL lope - jog over
- 6 RL Lope over - walk
- 7 Work gate
- 8 Back up
- 9 Walk - LL Lope over
- 10 Jog over
- 11 Walk bridge

→	Lope / Galop	→	Extended Lope / Galop allongé
- - -	Jog	- - -	Extended Jog / Trot
⋯	Walk / Pas	↻	Turn / pivot
●	Marker -/cône	⚡	Backup / reculer

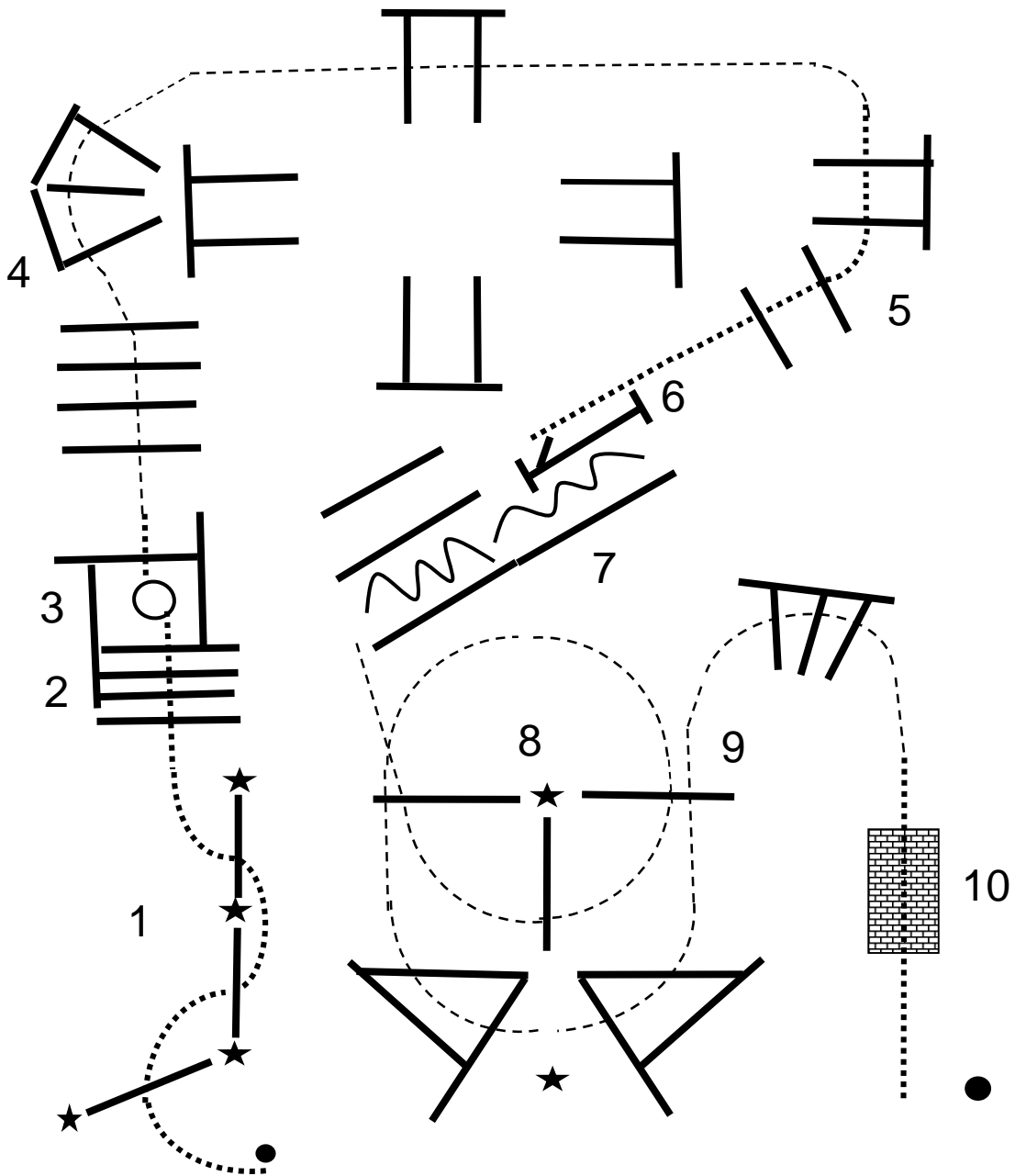

- 1 Walk over
- 2 Walk over 4 logs
- 3 360° either side- walk out
- 4 Jog over
- 5 Walk over
- 6 Work gate
- 7 Back up
- 8 Jog over
- 9 Jog over
- 10 Walk bridge

	Lope / Galop		Extended Lope / Galop allongé
	Jog		Extended Jog / Trot
	Walk / Pas		Turn / pivot
	Marker -/cône		Backup / reculer

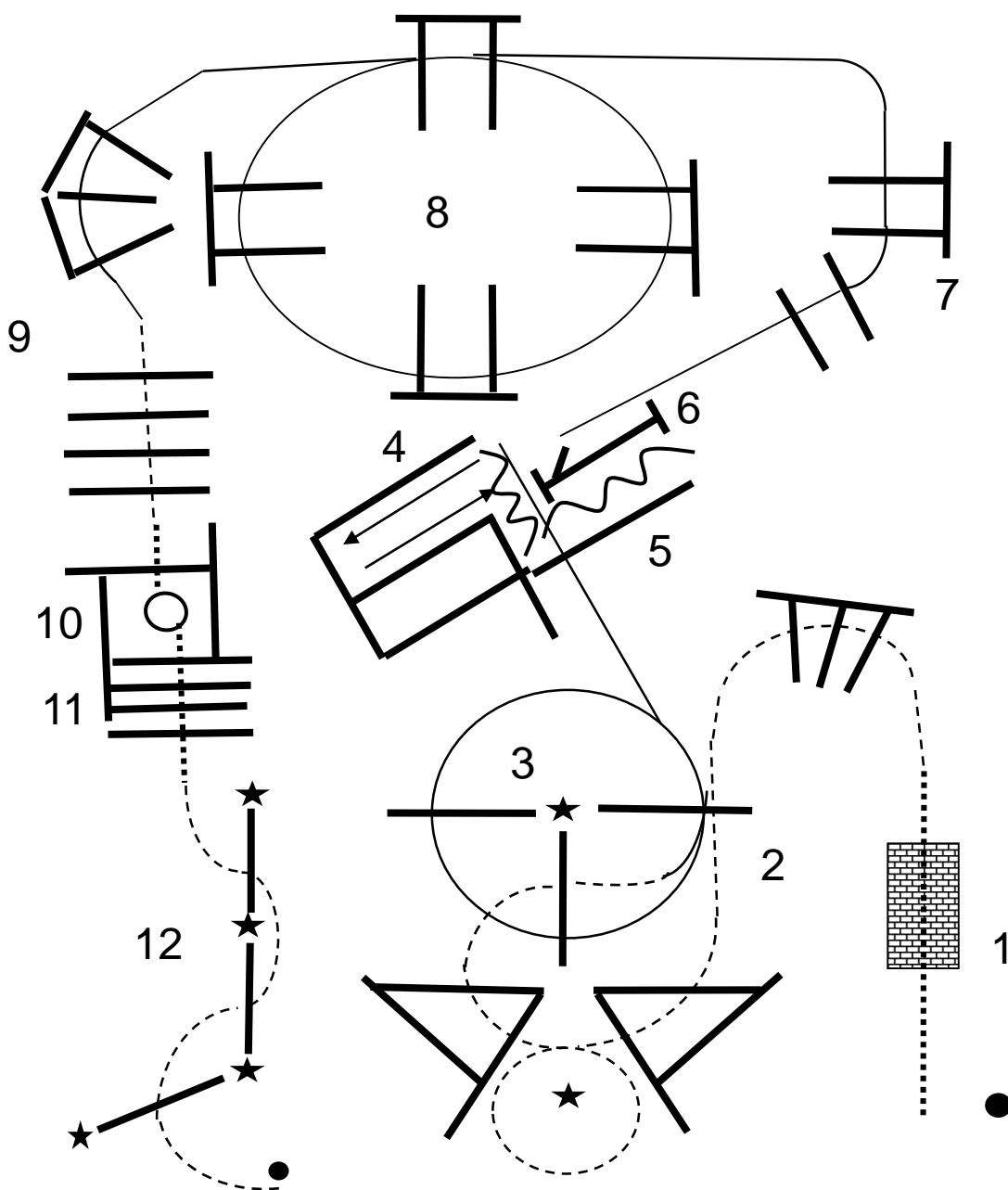

- 1 Walk over bridge
- 2 Jog over as drawn
- 3 LL lope over and in
- 4 left and right side pass
- 5 Backup
- 6 Work gate
- 7 LL lope over
- 8 LL lope over
- 9 Jog over – walk in
- 10 360° either side
- 11 Walk over
- 12 Jog over

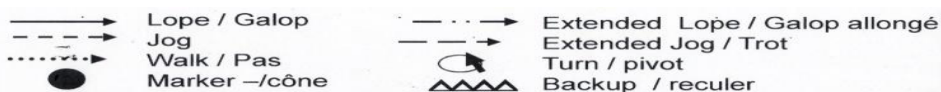

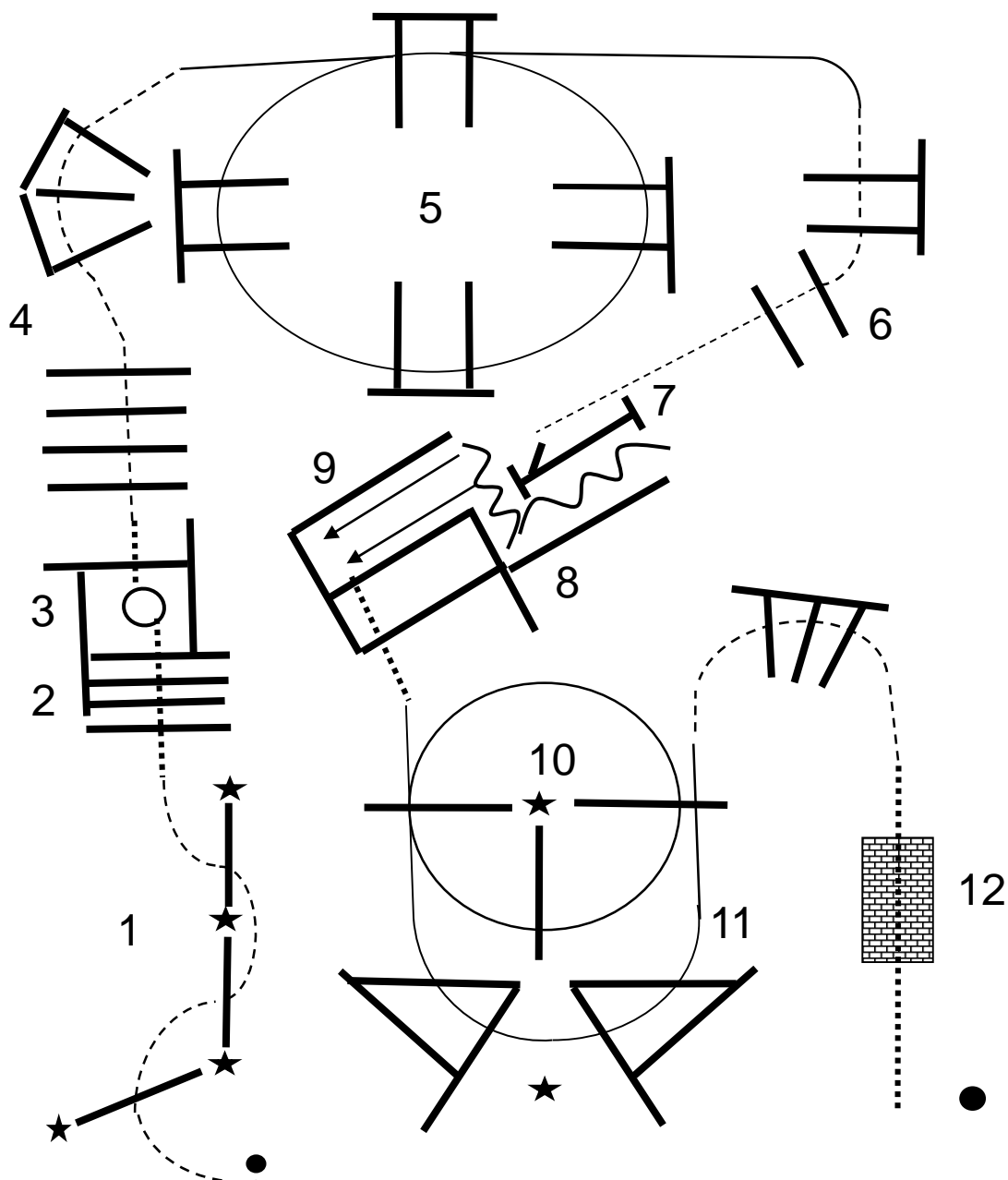



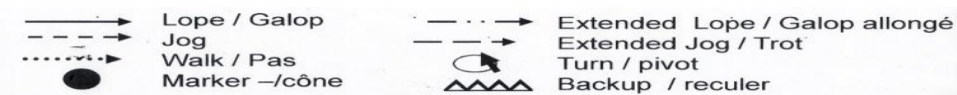

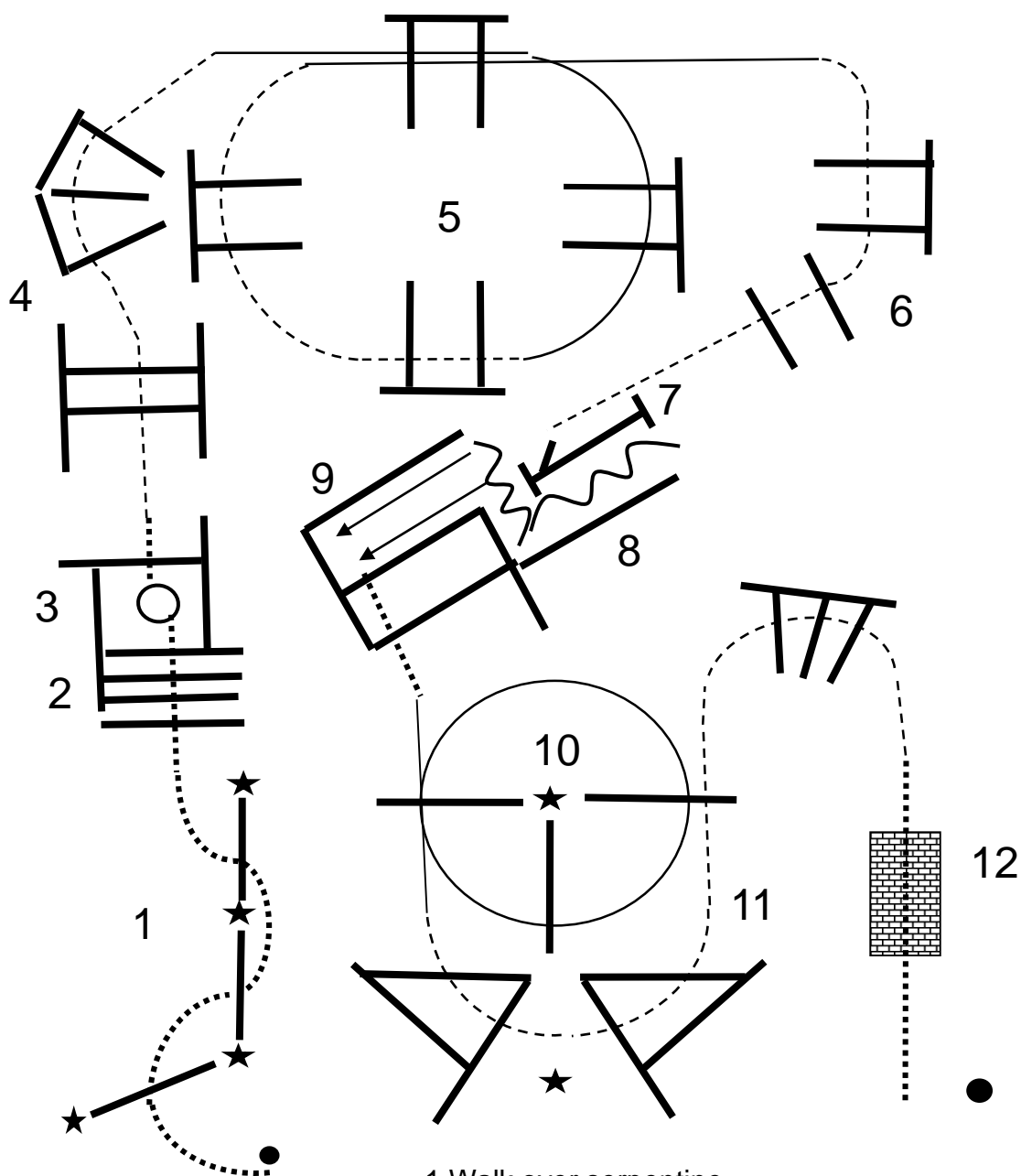
- 1 Jog over
- 2 Walk over
- 3 360° either side - walk out
- 4 jog over
- 5 RL Lope over
- 6 Jog over
- 7 Work gate
- 8 Back up
- 9 Side pass right – walk out
- 10 Lope LL
- 11 Lope LL – jog
- 12 Walk bridge





- 1 Walk over serpentine
- 2 Walk over in
- 3 360° either side- walk out
- 4 Jog over
- 5 RL Lope over
- 6 Jog over
- 7 Work gate
- 8 Back up
- 9 Side pass right – walk out
- 10 LL Lope over
- 11 Jog over
- 12 Walk bridge

 Lope / Galop
 Jog
 Walk / Pas
 Marker –/cône

 Extended Lope / Galop allongé
 Extended Jog / Trot
 Turn / pivot
 Backup / reculer